

Data Sheet

ROYTRONIC EXCEL™ Series AD

Electronic Metering Pumps

Model AD 2 5 1 - 8 3 8 S I

Model Code Configuration

Drive

Control Code

2 - **Dual Manual Control**
Stroke frequency and length manually adjustable, LCD display, low level indication (remote input). Display configurable to indicate theoretical pump flow.

8 - **Pulse/Analog Input w/ Dual Manual Control**
Pulse or 4-20 mA signal input controls frequency, LCD display, manual stroke length control, frequency manually adjustable when in local control, pulse multiply/divide functions, 24 V output for remote device. Includes dual low level float switch input. Display configurable to indicate theoretical pump flow.

9 - **Pulse/Analog Input w/Dual Manual Control & Enhanced Controls**
Advanced Features - Pulse or 4/20 mA signal input controls frequency, graphical display, manual stroke length control, Frequency manually adjustable when in local control, Pulse multiply/divide functions, 24 V output for remote device, dual low level float switch input, Remote on/off signal input. Outputs include: 4-20 mA, pulse, & Alarm. Remote internal/external mode input. Display configurable to indicate theoretical pump flow.

Output Code with FastPrime™ Liquid End

Max Capacity	Max Pressure
1 - 0.21 GPH (0.8 l/h)	250 psi (17.2 Bar)
4 - 0.5 GPH (1.9 l/h)	250 psi (17.2 Bar)
5 - 1.0 GPH (3.8 l/h)	110 psi (7.6 Bar)
6 - 2.0 GPH (7.6 l/h)	50 psi (3.4 Bar)

Voltage Code

1 - 110-120V US Plug
2 - 220-240V US Plug
3 - 220-240V DIN Plug
5 - 220-240V UK Plug
6 - 220-240V Aust/NZ Plug
7 - 220-240V Swiss Plug
8 - 110-120V No Plug

Liquid End

Liquid End Code
See Accompanying Pages for Options

Liquifram™ Size Code

1 - 0.2 in²
2 - 0.4 in²
3 - 0.8 in²
4 - 1.6 in²

Material Code
See Accompanying Pages for Options

Head/Valve Code

S - FastPrime™ Head + 4FV V - High Viscosity Head
N - FastPrime™ Head P - High Viscosity with Ported Head
H - AutoPrime™ Head + 4FV
A - AutoPrime™ Head

Connection Code

I - Inch Tube connections with tubing
M - Metric Tube connection without tubing
U - Inch Tube connection with Black UV resistant suction/discharge tubing
P - 1/2" NPT - 1/2" BSP Pipe (SS 1/4" NPT)

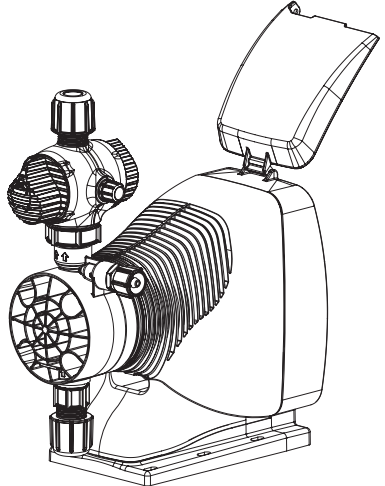
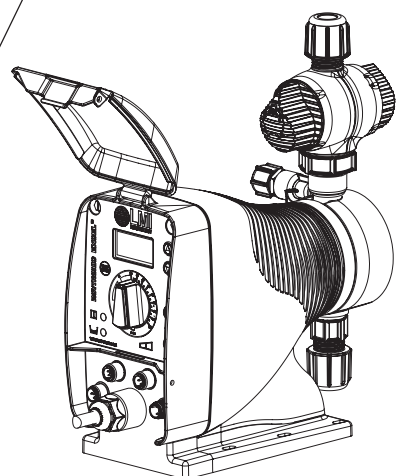

Specifications

Series	Strokes Per Minute (Adjustable)		Stroke Length (Adjustable) Recommended Minimum	Average Input Power @ Max Speed and Pressure	Max. Shipping Weight
	Min	Max			
AD 2X* AD 8X* AD 9X*	1	120	20%	25 watts	10 lbs (4.75 kg)

* where X = output code



201 Ivyland Road
Ivyland, PA 18974 USA
TEL: (215) 293-0401
FAX: (800) 327-7563
<http://www.lmipumps.com>

Standard FastPrime™ Liquid End Configuration Data & Materials of Construction

Drive Assembly	Liquid End	Size Code	Materials of Construction				Accs. Valve	Tubing & Connections Discharge & Suction
			Head/Fittings	Balls	Liquifram™	Seat/O-Ring		
AD91 ■ AD81 ■ AD21 ■	910SI†	1	Acrylic/PVC	Ceramic	Fluorofilm™	PTFE/Polyprel®	4FV	PE 1/4" O.D.
	915SI†	1	PP/PP	Ceramic	Fluorofilm™	PTFE	4FV	PE 1/4" O.D.
	918SI†	1	PVC/PVC	Ceramic	Fluorofilm™	PTFE/Polyprel®	4FV	PE 1/4" O.D.
	919SI†	1	Acrylic/PVDF	PTFE	Fluorofilm™	PTFE/Polyprel®	4FV	PE 1/4" O.D.
	917NP	1	316ss/316ss	316ss	Fluorofilm™	316ss/PTFE	—	1/4" NPT
	812SI†	1	PVDF/PVDF	Ceramic	Fluorofilm™	PTFE/Polyprel®	4FV	PE 1/4" O.D.
	813SI†	1	PVDF/PVDF	Ceramic	Fluorofilm™	PTFE	4FV	PE 1/4" O.D.
	818SI†	1	PVC/PVC	Ceramic	Fluorofilm™	PTFE/Polyprel®	4FV	PE 1/4" O.D.
718SI†	1	PVC/PVC	Ceramic	Fluorofilm™	PTFE/Polyprel®	4FV	PE 1/4" O.D.	

Drive Assembly	Liquid End	Size Code	Materials of Construction				Accs. Valve	Tubing & Connections Discharge & Suction
			Head/Fittings	Balls	Liquifram™	Seat/O-Ring		
AD94 ■ AD84 ■ AD24 ■	920SI†	2	Acrylic/PVC	Ceramic	Fluorofilm™	Polyprel®	4FV	PE 1/4" O.D.
	925SI†	2	PP/PP	Ceramic	Fluorofilm™	PTFE	4FV	PE 1/4" O.D.
	928SI†	2	PVC/PVC	Ceramic	Fluorofilm™	Polyprel®	4FV	PE 1/4" O.D.
	929SI†	2	Acrylic/PVDF	PTFE	Fluorofilm™	Polyprel®	4FV	PE 1/4" O.D.
	927NP	2	316ss/316ss	316ss	Fluorofilm™	316ss/PTFE	—	1/4" NPT
	822SI†	2	PVDF/PVDF	Ceramic	Fluorofilm™	Polyprel®	4FV	PE 1/4" O.D.
	823SI†	2	PVDF/PVDF	Ceramic	Fluorofilm™	PTFE	4FV	PE 1/4" O.D.
	828SI†	2	PVC/PVC	Ceramic	Fluorofilm™	Polyprel®	4FV	PE 1/4" O.D.
	728SI†	2	PVC/PVC	Ceramic	Fluorofilm™	Polyprel®	4FV	PE 1/4" O.D.
	624VI*	2	PP/PP	316ss	Fluorofilm™	PTFE	—	PE.5" O.D. Vinyl.938" O.D.
626VI	2	Acrylic/PP	316ss	Fluorofilm™	Viton®/ Polyprel®	—	PE.5" O.D. Vinyl.938" O.D.	

Drive Assembly	Liquid End	Size Code	Materials of Construction				Accs. Valve	Tubing & Connections Discharge & Suction
			Head/Fittings	Balls	Liquifram™	Seat/O-Ring		
AD95 ■ AD85 ■ AD25 ■	930SI†	3	Acrylic/PVC	Ceramic	Fluorofilm™	Polyprel®	4FV	PE 3/8" O.D.
	935SI†	3	PP/PP	Ceramic	Fluorofilm™	PTFE	4FV	PE 3/8" O.D.
	938SI†	3	PVC/PVC	Ceramic	Fluorofilm™	Polyprel®	4FV	PE 3/8" O.D.
	939SI†	3	Acrylic/PVDF	PTFE	Fluorofilm™	Polyprel®	4FV	PE 3/8" O.D.
	937NP	3	316ss/316ss	316ss	Fluorofilm™	316ss/PTFE	—	1/4" NPT
	832SI†	3	PVDF/PVDF	Ceramic	Fluorofilm™	Polyprel®	4FV	PE 3/8" O.D.
	833SI†	3	PVDF/PVDF	Ceramic	Fluorofilm™	PTFE	4FV	PE 3/8" O.D.
	838SI†	3	PVC/PVC	Ceramic	Fluorofilm™	Polyprel®	4FV	PE 3/8" O.D.
	738SI†	3	PVC/PVC	Ceramic	Fluorofilm™	Polyprel®	4FV	PE 3/8" O.D.
	634VI*	3	PP/PP	316ss	Fluorofilm™	PTFE	—	PE.5" O.D. Vinyl.938" O.D.
	636VI	3	Acrylic/PP	316ss	Fluorofilm™	Viton®/ Polyprel®	—	PE.5" O.D. Vinyl.938" O.D.

Drive Assembly	Liquid End	Size Code	Materials of Construction				Accs. Valve	Tubing & Connections Discharge & Suction
			Head/Fittings	Balls	Liquifram™	Seat/O-Ring		
AD96 ■ AD86 ■ AD26 ■	940SI†	4	Acrylic/PVC	Ceramic	Fluorofilm™	Polyprel®	4FV	PE 3/8" O.D.
	945SI†	4	PP/PP	Ceramic	Fluorofilm™	PTFE	4FV	PE 3/8" O.D.
	948SI†	4	PVC/PVC	Ceramic	Fluorofilm™	Polyprel®	4FV	PE 3/8" O.D.
	949SI†	4	Acrylic/PVDF	PTFE	Fluorofilm™	Polyprel®	4FV	PE 3/8" O.D.
	947NP	4	316ss/316ss	316ss	Fluorofilm™	316ss/PTFE	—	1/4" NPT
	842SI†	4	PVDF/PVDF	Ceramic	Fluorofilm™	Polyprel®	4FV	PE 3/8" O.D.
	843SI†	4	PVDF/PVDF	Ceramic	Fluorofilm™	PTFE	4FV	PE 3/8" O.D.
	848SI†	4	PVC/PVC	Ceramic	Fluorofilm™	Polyprel®	4FV	PE 3/8" O.D.
	748SI†	4	PVC/PVC	Ceramic	Fluorofilm™	Polyprel®	4FV	PE 3/8" O.D.
	644VI*	4	PP/PP	316ss	Fluorofilm™	PTFE	—	PE.5" O.D. Vinyl.938" O.D.
646VI	4	Acrylic/PP	316ss	Fluorofilm™	Viton®/ Polyprel®	—	PE.5" O.D. Vinyl.938" O.D.	

Output Information with FastPrime™ Liquid End

Series	Gallons per Hour		Liters per Hour		mL/cc per Minute		mL/cc per Stroke		Maximum Injection Pressure
	Min	Max	Min	Max	Min	Max	Min	Max	
ADX1	0.002	0.21	0.01	0.8	0.132	13.2	0.011	0.11	250 psi (17.2 Bar)
ADX4	0.005	0.5	0.02	1.9	0.315	31.5	0.026	0.26	250 psi (17.2 Bar)
ADX5	0.01	1.0	0.04	3.8	0.630	63.0	0.053	0.53	110 psi (7.6 Bar)
ADX6	0.02	2.0	0.08	7.6	1.260	126.0	0.105	1.05	50 psi (3.4 Bar)

(Where X = Control Code 2,8,9).

AutoPrime™ Liquid End Configuration Data & Materials of Construction

Drive Assembly	Liquid End	Size Code	Materials of Construction				Accs. Valve	Tubing & Connections
			Head/Fittings	Balls	Liquifram™	Seat/O-Ring		
AD91 ■ AD81 ■ AD21 ■	A10HI†	1	Acrylic/PVC	Ceramic**	Fluorofilm™	PTFE/Polyprel®	4FV	PE 1/4" O.D.
	A18HI†	1	PVC/PVC	Ceramic**	Fluorofilm™	PTFE/Polyprel®	4FV	PE 1/4" O.D.

Drive Assembly	Liquid End	Size Code	Materials of Construction				Accs. Valve	Tubing & Connections
			Head/Fittings	Balls	Liquifram™	Seat/O-Ring		
AD94 ■ AD84 ■ AD24 ■	A20HI†	2	Acrylic/PVC	Ceramic**	Fluorofilm™	PTFE/Polyprel®	4FV	PE 1/4" O.D.
	A28HI†	2	PVC/PVC	Ceramic**	Fluorofilm™	PTFE/Polyprel®	4FV	PE 1/4" O.D.

Drive Assembly	Liquid End	Size Code	Materials of Construction				Accs. Valve	Tubing & Connections
			Head/Fittings	Balls	Liquifram™	Seat/O-Ring		
AD95 ■ AD85 ■ AD25 ■	A30HI†	3	Acrylic/PVC	Ceramic**	Fluorofilm™	PTFE/Polyprel®	4FV	PE 3/8" O.D.
	A38HI†	3	PVC/PVC	Ceramic**	Fluorofilm™	PTFE/Polyprel®	4FV	PE 3/8" O.D.

Drive Assembly	Liquid End	Size Code	Materials of Construction				Accs. Valve	Tubing & Connections
			Head/Fittings	Balls	Liquifram™	Seat/O-Ring		
AD96 ■ AD86 ■ AD26 ■	A40HI†	4	Acrylic/PVC	Ceramic**	Fluorofilm™	PTFE/Polyprel®	4FV	PE 3/8" O.D.
	A48HI†	4	PVC/PVC	Ceramic**	Fluorofilm™	PTFE/Polyprel®	4FV	PE 3/8" O.D.

Output Information with AutoPrime™ Liquid End — Estimated

Series	Gallons per Hour		Liters per Hour		mL/cc per Minute		mL/cc per Stroke		Maximum Injection Pressure
	Min	Max	Min	Max	Min	Max	Min	Max	
ADX1	0.0015	0.15	0.006	0.6	0.095	9.5	0.008	0.079	250 psi (17.2 Bar)
ADX4	0.0033	0.33	0.012	1.2	0.21	20.8	0.017	0.17	250 psi (17.2 Bar)
ADX5	0.008	0.8	0.030	3.0	0.50	50.5	0.042	0.42	110 psi (7.6 Bar)
ADX6	0.018	1.8	0.068	6.8	1.14	113.6	0.095	0.95	50 psi (3.4 Bar)

(Where X = Control Code 2,8,9).

AUTOPRIME™ liquid ends have 3 check valves: suction on the bottom; discharge on the front; autopriming bleed on the top. By design, a repeatable portion of the process fluid continuously bleeds through the top check valve to be returned to the chemical supply. The result is the assurance that any gas in the head is automatically relieved thus eliminating air-binding. Depending on application, output may be reduced up to 50%. Variables include supplier piping, stroke length and speed setting.

■ See front page for voltage code specifications.

† To specify black, UV resistant tubing, change 'I' to 'U'. To specify head only and no 4FV, change S to N for FastPrime or change H to A for AutoPrime.

To specify 1/2" NPT Male, change "I" to "P".

* To specify Ported Head, change "V" to "P".

** Autoprime™ cartridge ball is Hastelloy.

4FV indicates that the pump is equipped with an LMI Four Function Valve. This diaphragm type, anti-syphon/pressure relief valve is installed on the pump head. It provides anti-syphon protection and aids priming, even under pressure.

Fluorofilm™ is a copolymer of PTFE and PFA. Polyprel® is an elastomeric PTFE copolymer.

Polyprel is a registered trademark of the Milton Roy Company.

Fluorofilm and Liquifram are trademarks of the Milton Roy Company.

Viton® is a registered trademark of E.I. du Pont Company.

MOUNTING INFORMATION

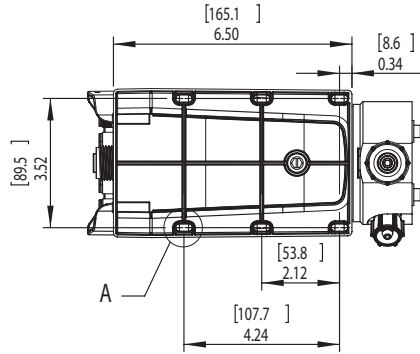
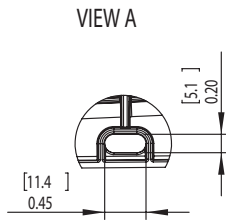

FASTPRIME LIQUID ENDS

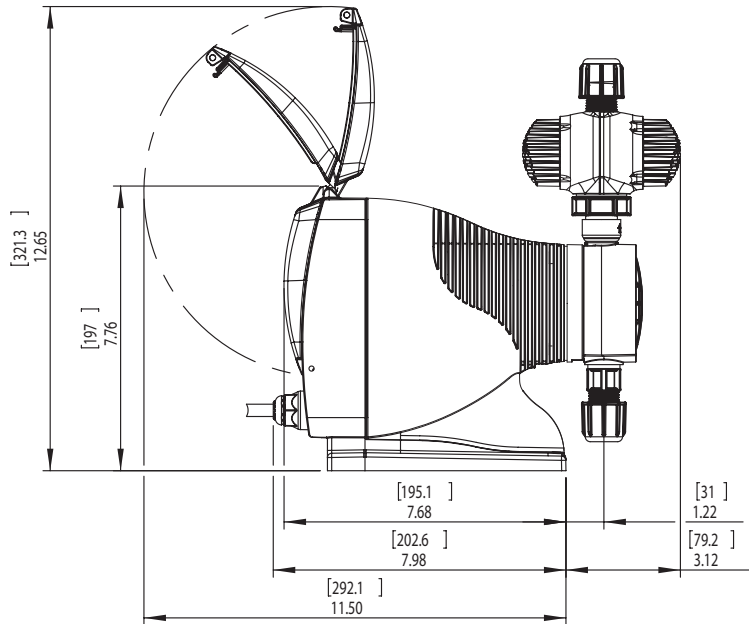
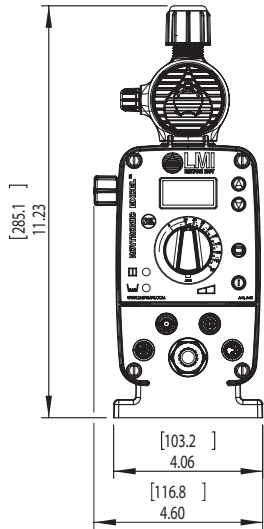

AUTOPRIME LIQUID ENDS

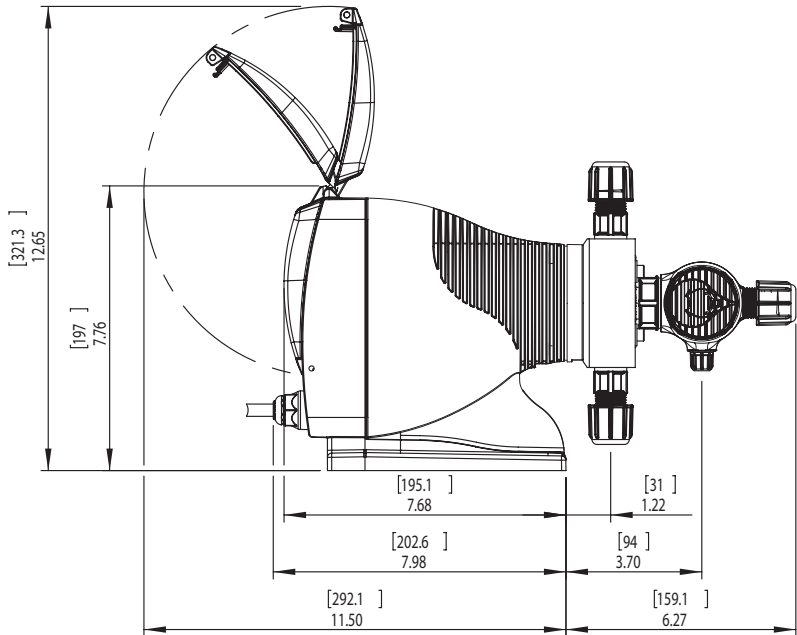
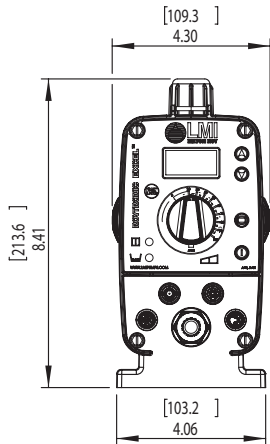

NOTE: ALL DIMENSIONS ARE IN INCHES [MM]. DIMENSIONS SHOWN ARE FOR LARGEST LIQUID END.
DIMENSIONS WILL VARY DEPENDING ON LIQUID END SELECTED.