



High Viscosity LE- 6X4VI, 6X4PI, 6X6VI

When pumping solutions, make certain that all tubing is securely attached to the fittings. It is recommended that tubing or pipe lines be shielded to prevent possible injury in case of rupture or accidental damage. Always wear protective clothing and face shield when working on or near your metering pump.

For use on ROYTRONIC EXCEL™ Series pumps.

Note: See parts list for materials of construction.

A. INSTALLING INJECTION CHECK VALVE (FIGURE 1)

1. The Injection Check Valve prevents backflow from a treated line. Install the injection check valve at the location where chemical is being injected into the system.
2. Any size Female NPT fitting or pipe tee with a reducing bushing to ½" Female NPT will accept the injection check valve. PTFE tape should only be used on threads that are connected with pipes.
3. When installing the Injection Check Valve, be sure to position it so that the valve enters the bottom of your pipe in a vertical position. Variations 40° left and right are acceptable.

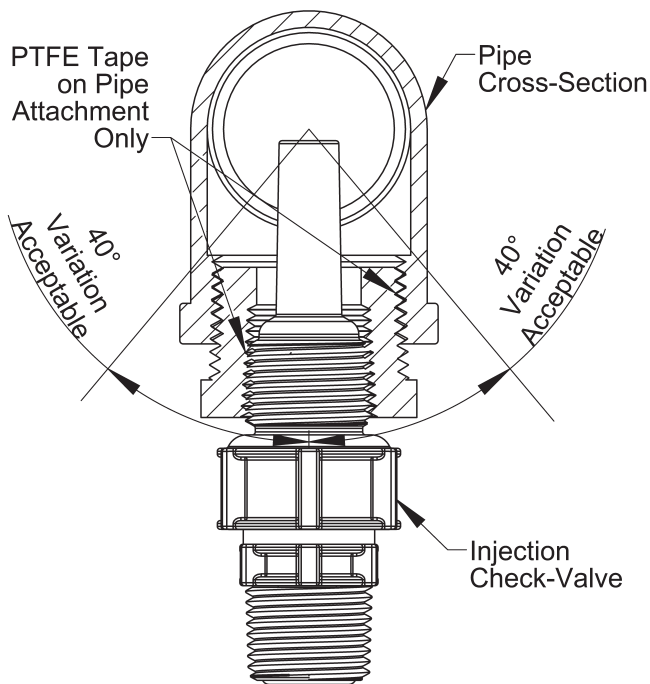

FIGURE 1

B. CONNECTING DISCHARGE TUBING

Note: Cut tubing to length needed for discharge line.

1. Route tubing from the injection check valve to the metering pump, making sure it does not touch hot or sharp surfaces, or is bent so sharply that it kinks.
2. Slide the small end of the coupling nut onto tubing, then slide on the clamp ring.
3. Push tubing on the valve housing nozzle so that tubing flares out and butts up against valve housing and will not go any further.
4. Slide the clamp ring and coupling nut to the threads and engage. While pushing the tubing onto the valve housing nozzle, tighten the coupling nut by hand until tubing is held securely in place.

DO NOT USE CLEAR VINYL TUBING ON THE DISCHARGE SIDE OF THE PUMP. The pressure created by the pump can rupture vinyl tubing, which is only for suction connections on certain liquid ends.

DO NOT USE PLIERS OR PIPE WRENCH ON COUPLING NUTS OR FITTINGS. USE ONLY LMI TUBING—ALWAYS use LMI supplied tubing with your pump, as the tubing is specifically designed for use with the pump fittings.



201 Ivyland Road
Ivyland, PA 18974 USA
TEL: (215) 293-0401
FAX: (215) 293-0445
<http://www.lmipumps.com>

LE- 6X4VI, 6X4PI, 6X6VI

Key Number	Description	Part Number	QUANTITY			QUANTITY			QUANTITY		
			624VI	634VI	644VI	624PI	634PI	644PI	626VI	636VI	646VI
10	Pump Head	49329							1		
		49331	1								
		49332				1					
		49334								1	
		49336		1							
		49337					1				
		49339									1
		49341			1						
		49342						1			
23	Valve Housing	25173	1	1	1	1	1	1	1	1	
28	Valve Seat, Barbed	25649	1	1	1	1	1	1	1	1	
29	Valve Seat	25106	1	1	1	1	1	1	1	1	
30	Coupling Nut	10411	2	2	2	2	2	2	2	2	
65	Spring	25558	2	2	2	2	2	2	2	2	
70	Ball	25042	3	3	3	3	3	3	3	3	
80	Seal Ring	10228							3	3	3
		25128	3	3	3	3	3	3			
110	Plug	26558				1	1	1			
190	Liquifram™	48187	1			1			1		
		48188		1			1			1	
		48189			1			1			1
230	Injection Check Valve Body	25108	1	1	1	1	1	1	1	1	
255	Barbed Connector	25650	1	1	1	1	1	1	1	1	
276	Hose Clamp	25652	2	2	2	2	2	2	2	2	
280	Clamp Ring	37203	2	2	2	2	2	2	2	2	
350	Tubing, Discharge 9XXHI ONLY	10142-10	1	1	1	1	1	1	1	1	
358	Tubing, Suction	25651-3.5	1	1	1	1	1	1	1	1	
601	Discharge Check Valve	49393							1	1	1
		49392	1	1	1	1	1	1			
602	Suction Check Valve	49397							1	1	1
		49396	1	1	1	1	1	1			
606	Liquid End Hardware	48702	1	1	1	1	1	1	1	1	
608	Injection Valve	49389							1	1	1
		49388	1	1	1	1	1	1			

LE- 6X4VI, 6X4PI, 6X6VI

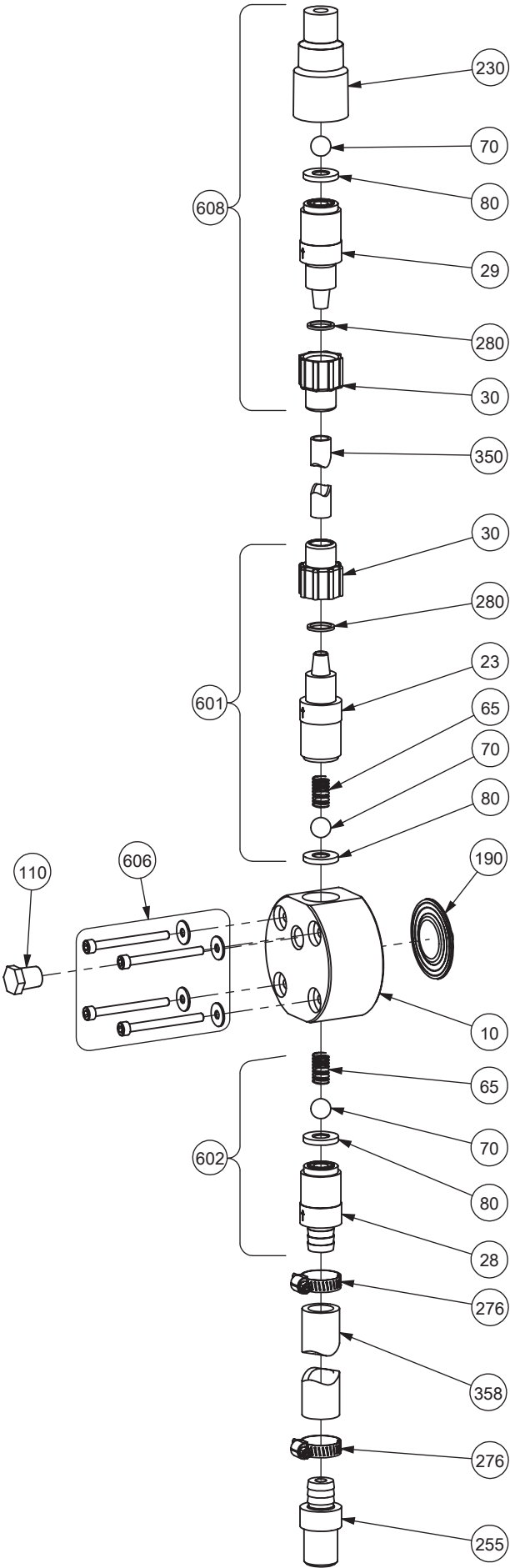

C. CONNECTING SUCTION TUBING

Flooded Suction (Preferred Method)

1. Mount pump 12" above the floor with the head extending beyond mounting surface so the suction tubing curves gently away from the pump to prevent kinking.
2. Install 1/2" or 3/4" NPT shut off valve, with at least 3/4" clear way through the valve, into reservoir. This is necessary to stop flow from reservoir while servicing the pump.
3. Install barbed connector (one [1] of two [2] supplied) into the valve. Attach 15/16" O.D. Vinyl tubing to the barbed connector. Secure with the hose clamp provided. (Use shortest length of suction tubing necessary.)
4. Connect the other end of the suction fitting at the pump and secure with the hose clamp provided.

D. CONNECTING SUCTION TUBING

Suction lift (Pump Sitting on Barrel: Maximum Lift 3.5 ft.)

1. Connect the suction tubing to the barbed suction fitting on the pump. Secure with the hose clamp provided.
2. Cut tubing so it will only reach within 1" of the bottom of the barrel.
3. If tubing curl is a problem, fabricate a 1" Polypropylene or PVC pipe as a tubing straightener. (Pipe should be slightly longer than the depth of the barrel for ease of removal.)
2. Place the tubing straightener over the suction tubing and lower into the barrel.

E. PRIMING

When all precautionary steps have been taken, the pump is mounted, and the tubing is securely attached, you may now start priming the pump.

1. Plug in or switch the pump on.
2. While the pump is running, set at 100% speed and 100% stroke length.
3. The suction tubing should begin to fill with solution from the tank.

4. A small amount of solution will begin to discharge out the discharge valve. Once this happens, **SHUT THE PUMP OFF.**

5. The pump is now primed.

Note: *The pumps are normally self priming if suction lift is less than 3.5 feet (1 meter), check valves are wet (there is usually water in the pump head when shipped from the factory), and the steps above are followed. If the pump does not self prime, see below:*

1. Remove the discharge valve housing and ball and slowly pour water or solution into the pump head until it is filled. Replace valve housing and ball and repeat steps above.
2. Temporarily improve suction conditions by pumping from a container closer to or above pump.
3. If difficulty is experienced on the initial prime, apply vacuum by suitable means, such as a hand suction pump. For 6XXVI and 6XXVP, apply vacuum to the discharge tubing or piping. For 6XXPI and 6XXPP, apply vacuum to the convenient primary port on the front of the pump head. Difficulty should not reoccur after pump is primed with a viscous liquid.

F. DEPRESSURIZING THE DISCHARGE LINE

ALWAYS wear protective clothing, face shield, safety glasses and gloves when performing any maintenance or replacement on your pump.

Read steps 1 and 2 below before proceeding.

1. Be sure the Injection Check Valve is properly installed and is operating. If a shut off valve has been installed downstream of the Injection Valve, it should be closed.
2. **Line Depressurization:**
To reduce the risk of chemical splash during disassembly or maintenance, all installations should be equipped with line depressurization capability.



When tubing connections are loosened, chemical will drain from the line. Use appropriate safety precautions to avoid contact with chemical.

REFER TO YOUR ELECTRONIC METERING PUMP INSTRUCTION MANUAL FOR ADDITIONAL INSTRUCTIONS AND PRECAUTIONS. You may contact your local LMI Distributor for additional information or visit LMI on the web at www.lmipumps.com