

Liquid End Sheet

LE-94S

When pumping solutions, make certain that all tubing is securely attached to the fittings. It is recommended that tubing or pipe lines be shielded to prevent possible injury in case of rupture or accidental damage. Always wear protective clothing and face shield when working on or near your metering pump.

Note: See parts list for materials of construction

A. INSTALLING INJECTION CHECK VALVE

1. The injection check valve should always be installed as close as possible to the point of solution injection, at the very end of the tubing run.
2. Purpose of injection check valve is to prevent backflow from treated line.
3. A 1/2" NPT female fitting with sufficient depth will accept the injection check valve.
4. To insure correct seating of the ball inside the check valve, the injection check valve must be installed vertically upwards.

B. CONNECTING DISCHARGE PIPE

Note:

Corrosion resistant 1/4" Schedule 80 pipe should be used. Do not use 1/8" pipe.

1. Discharge valve has 1/4" NPT male outlet. A 1/4" NPT union should be connected to both discharge and suction valves so that chemical metering pump may be removed without disturbing piping.

It is recommended that Teflon® tape be used on tapered pipe threads so that there is a leakproof seal without overtightening of fittings.

C. CONNECTING SUCTION PIPE

1. Using the same size and material pipe as used on discharge line, cut suction pipe to required length.

D. PRIMING

1. Connect pressure release tubing to pressure release port.

2. Route tubing to solution reservoir and anchor with plastic tie provided.
3. Start pump.
4. Turn Pressure Relief knob (black knob) 1/4 turn. Let pump run until solution is visible through translucent return tubing.
5. Turn Pressure Relief knob back 1/4 turn. The pump is now primed.

Note:

- (a) *Pump is normally self-priming if suction lift is not more than 5 ft (1.5 m), valves in the pump are wet with water (pump is shipped from factory with water in pump head) and the above steps (D. Priming) are followed.*
- (b) *If the pump does not self-prime, remove Anti-Syphon/Pressure Release Valve Assembly and discharge valve ball, and pour water or solution slowly into discharge port until head is filled. Replace valve ball and follow step D. Priming thereafter.*

E. DEPRESSURIZING DISCHARGE LINE

1. It is possible to depressurize the discharge line and pump head without removal of tubing or loosening of fittings.

Be sure injection check valve is properly installed and is operating. If a gate valve or globe has been installed downstream of injection check valve, it should be closed. Be certain relief tubing from the four function valve is connected and run to solution reservoir.

2. Pull on both anti-syphon and relief knobs.
3. The discharge line is now depressurized.



8 Post Office Square
Acton, MA 01720 USA
TEL: (978) 263-9800
FAX: (978) 264-9172
<http://www.lmipumps.com>



Replaces same of Rev. C 7/93
1486.D 11/97

NOTE:

Maximum pump pressure rating is reduced by 25 psi (1.7 bar) with back pressure spring (item 2 on exploded view) installed. **Do not remove back pressure spring if pressure at injection point is less than 20 psi (1.4 Bar).**

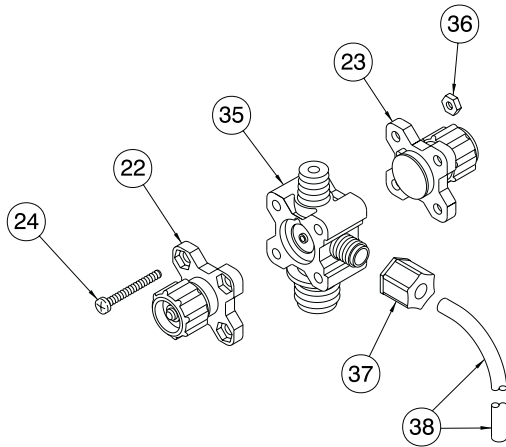

NOTE:

Threaded connections into pump head are 3/4" - 16 straight threads. **DO NOT USE TEFLON® TAPE.** These joints are sealed by seal ring valve seats (item 4 on exploded view).

KEY NO.	PART NO.	DESCRIPTION	QTY
2	10339*	Spring, PVDF	1
3	10338*	Ball, Ceramic, 3/8"	4
4	10407*	Seal Ring, PTFE	4
5	10492-1	Valve Seat	2
8	10493-1	Valve Housing	1
9	10340	Screw	4
10	30917*	Liquifram™, 0.9 Co-polymer	1
11	10213	Head, gray PVC, LE-94S, 0.9	1
13	10978	Foot Valve Seat	1
14	10123	Strainer	1
15	25029	Injection Valve Assembly	1
17	25031	Suction Valve Assembly	1
18	25032	Foot Valve Assembly	1
19	28440	Head Assembly, 94S	1
21	27051	Anti-Syphon/Pressure Release Valve	1
22	27044	Pressure Relief Cap Assembly	1
23	27045	Anti-Syphon Cap Assembly	1
24	25627	Screws	4
26	27352	Flapper Valve	1
27	26841	Injector Fitting	1
35	26856-1	Valve Body, PVDF 1/4" NPT	1
36	25628	Nut	4
37	25631	Ferrule Nut	1
38	25636-10	Tubing, .250" O.D. Polyethylene	1

*Parts included in Spare Parts Kit No. SP-U1.

