

When pumping solutions, make certain that all tubing is securely attached to the fittings. It is recommended that tubing or pipe lines be shielded to prevent possible injury in case of rupture or accidental damage. Always wear protective clothing and face shield when working on or near your metering pump.

Note: See parts list for materials of construction

## A. INSTALLING INJECTION CHECK VALVE (FIGURE 1)

Note: Not all configurations have an injection valve

1. The Injection Check Valve prevents backflow from a treated line. Install the injection check valve at the location where chemical is being injected into the system.
2. Any size Female NPT fitting or pipe tee with a reducing bushing to 1/2" Female NPT will accept the injection check valve. PTFE tape should only be used on threads that are connected with pipes.
3. When installing the Injection Check Valve, be sure to position it so that the valve enters the bottom of your pipe in a vertical position. Variations 40° left and right are acceptable.

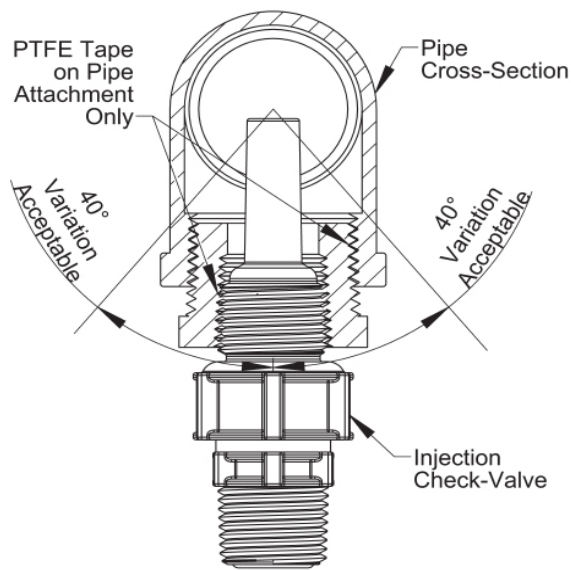

FIGURE 1

## B. CONNECTING DISCHARGE TUBING (FIGURE 2)

Note: Cut tubing to length needed for discharge line.

1. Route tubing from the injection check valve to the metering pump, making sure it does not touch hot or sharp surfaces, or is bent so sharply that it kinks.
2. Put coupling nut over tubing.
3. Position female Ferrule about one inch (25 mm) from end of tubing.

4. For 1/4" or 6 mm OD tubing, cut tubing so that 1/4" to 3/8" (5-10 mm) protrudes from the female Ferrule. For all other tubing push the tube to the bottom of the groove in the male Ferrule. Then slide the female Ferrule down into the male Ferrule.
5. Firmly hand tighten the coupling nut onto the fitting.

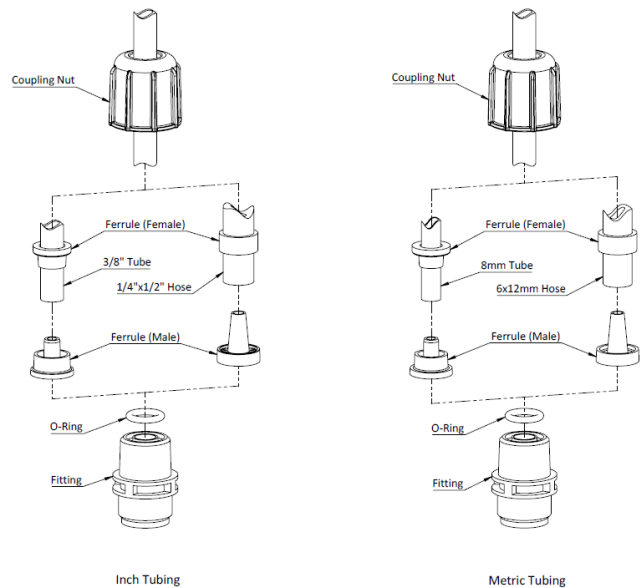

FIGURE 2

DO NOT USE CLEAR VINYL TUBING ON THE DISCHARGE SIDE OF THE PUMP.

DO NOT USE PLIERS OR PIPE WRENCH ON COUPLING NUTS OR FITTINGS.

## C. CONNECTING SUCTION TUBING/FOOT VALVE

Note: High-viscosity liquid ends are not equipped with a foot valve. Flooded suction is recommended. 1/2" NPT connector is included for flooded suction installations.

1. The foot valve acts as a check valve to keep the pump primed in suction lift applications. Cut suction tubing to a length so that the foot valve hangs approximately 2 in (50 mm) above the bottom of the solution container. Please refer to Figures 3 and 4 for proper foot valve positioning. Maximum recommended vertical suction lift is 13.1 ft (4 m) for Output Codes 2 & 3 and 6.5 ft (2 m).

2. The ceramic weight, when installed, helps position foot valve in a vertical position. Attach the foot valve to one end of the suction tubing and slide the ceramic weight over the tubing end until it contacts the top of the foot valve coupling nut. Place foot valve and tubing into solution tank.

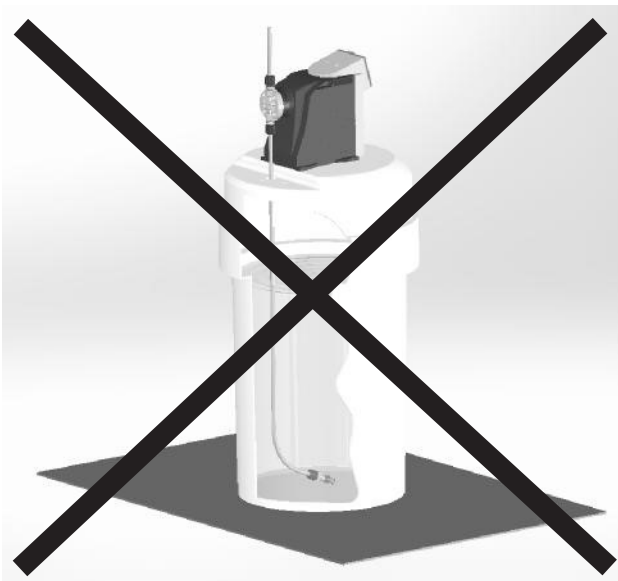

**FIGURE 3** - Incorrect Foot Valve Installation

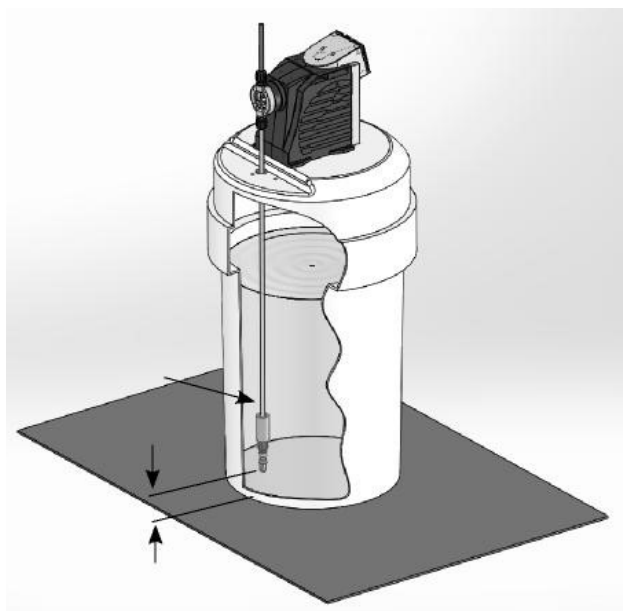

**FIGURE 4** - Correct Foot Valve Installation

## D. PRIMING

1. Prime the pump by pressing PRIME . The pump will operate at the flow rate and for the duration configured in the settings menu for the prime feature.
2. For more information on the prime feature, please refer to Section 4.5 the EXCEL XR Operation Manual available by searching for "Excel XR" on support.lmipumps.com or scanning the QR code below.



When tubing connections are loosened, chemical will drain from the line. Use appropriate safety precautions to avoid contact with chemical.

REFER TO THE EXCEL XR INSTRUCTION MANUAL FOR ADDITIONAL INSTRUCTIONS AND PRECAUTIONS.

You may contact your local LMI Distributor for additional information or visit LMI on the web at [www.lmipumps.com](http://www.lmipumps.com)

Specifications subject to change without notice.  
EXCEL® is a registered trademark of Milton Roy, LLC.  
© 2018 Milton Roy, LLC — All rights reserved.

1/2" FNPT

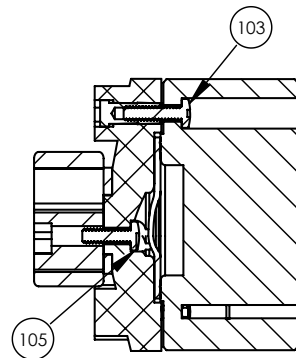
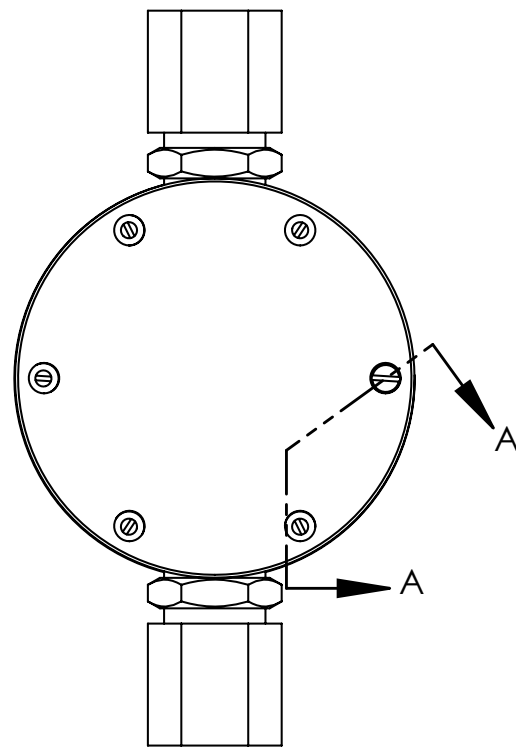
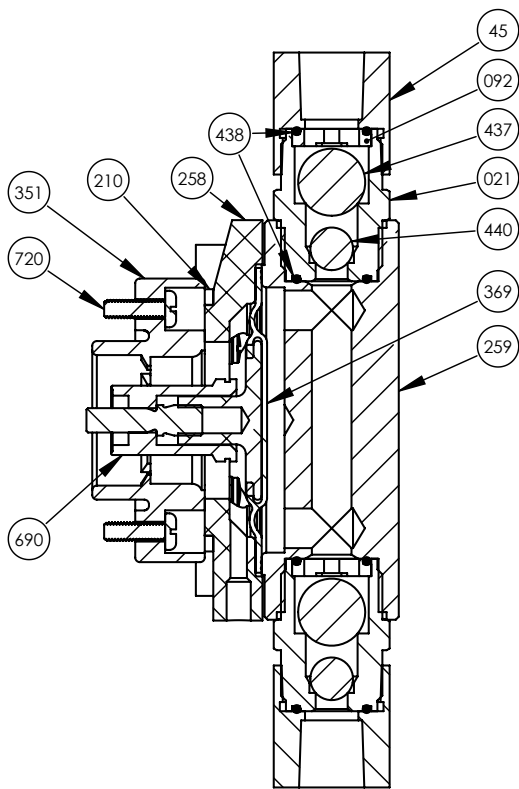

SECTION A-A

Key Number	Description	Part Number	Quantity
			S1614V1PN
21	BALL GUIDE	0210696016N	2
45	THREAD ADAPTER	0450420016N	2
92	BALL STOP	0920064016N	2
103	SCREW, HEAD	10340	6
105	SCREW, LE ADAPTER	10598	4
210	CENTERING WASHER	1199959881N	1
258	DIAPHRAGM ADAPTER	38856	1
259	HEAD	70034	1
351	LE SPACER	70114	1
353	SECONDARY DIAPHRAGM (BOOT)*	35330	1
369	DIAPHRAGM	36953	1
437	BALL	4370002224N	2
438	O-RING	4380051072N	4
440	BALL	4370002144N	2
690	DIAPHRAGM SPACER	70056	1
720	SCREW, LE SPACER	70054	4

\*Boot not shown in drawing