

Information Sheet

Motorized Blowdown Valves

The Worcester Controls' *Motorized Blowdown Valve* is an integral part of LMI's *Boiler Conductivity Monitor and Blowdown System*. The "Series 75" or "Series 36" valve is opened or closed by the controller to regulate the amount of water drained from the steam drum for conductivity control.

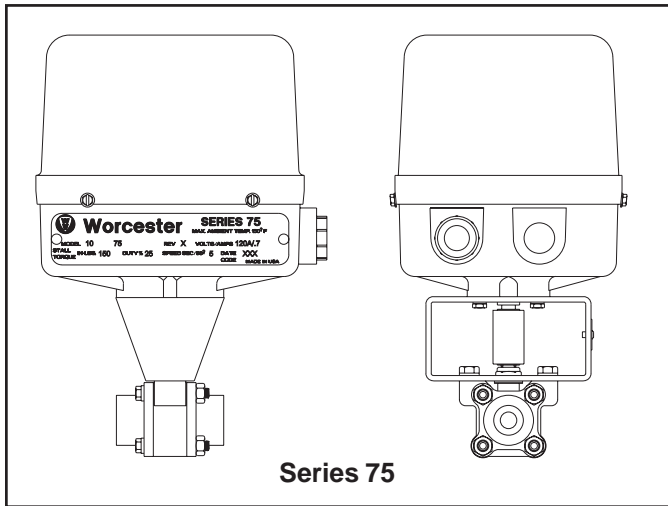

PART NO.	VALVE	ACTUATOR
35218	1/2"	10-75 Reversing Direction
35219	3/4"	10-75 Reversing Direction
35214		Actuator Only (No Valve)

SPECIFICATIONS		
Actuator	Enclosure	NEMA 1
	Torque	120 in/lbs
	Voltage	120 VAC
Valve	Pressure	400 psi (27.6 Bar)
	Temperature	400° F (204° C)
	Body	Carbon Steel
	Ball & Stem	316 S.S.
Seat	Polyfill/ANSI B 16.34 NPT Ends	

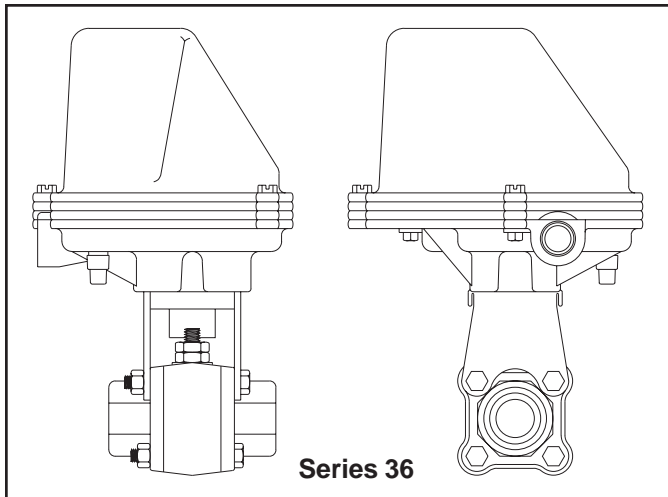

PART NO.	VALVE	ACTUATOR
35216	1/2"	10-36 Unidirectional
35217	3/4"	10-36 Unidirectional
35213		Actuator Only (No Valve)

SPECIFICATIONS		
Actuator	Enclosure	NEMA 1
	Torque	120 in/lbs
	Voltage	120 VAC
Valve	Pressure	400 psi (27.6 Bar)
	Temperature	400° F (204° C)
	Body	Carbon Steel
	Ball & Stem	316 S.S.
Seat	Polyfill/ANSI B 16.34 NPT Ends	

Proper installation and mounting of the motorized Ball Valve is important. Follow manufacturer's installation guide as closely as local conditions permit. An internal thermal overload switch prohibits operation if temperature inside actuator exceeds 250° F (120° C). Actuators and valves must be installed in the upright vertical position. They will not operate if mounted at an angle or if the actuator is under the valve.

LMI and Worcester Controls are both ISO 9001 certified companies. This stringent system of quality control ensures excellence in design, manufacture and customer service.



201 Ivyland Road
Ivyland, PA 18974 USA
TEL: (215) 293-0401
FAX: (215) 293-0445
<http://www.lmipumps.com>



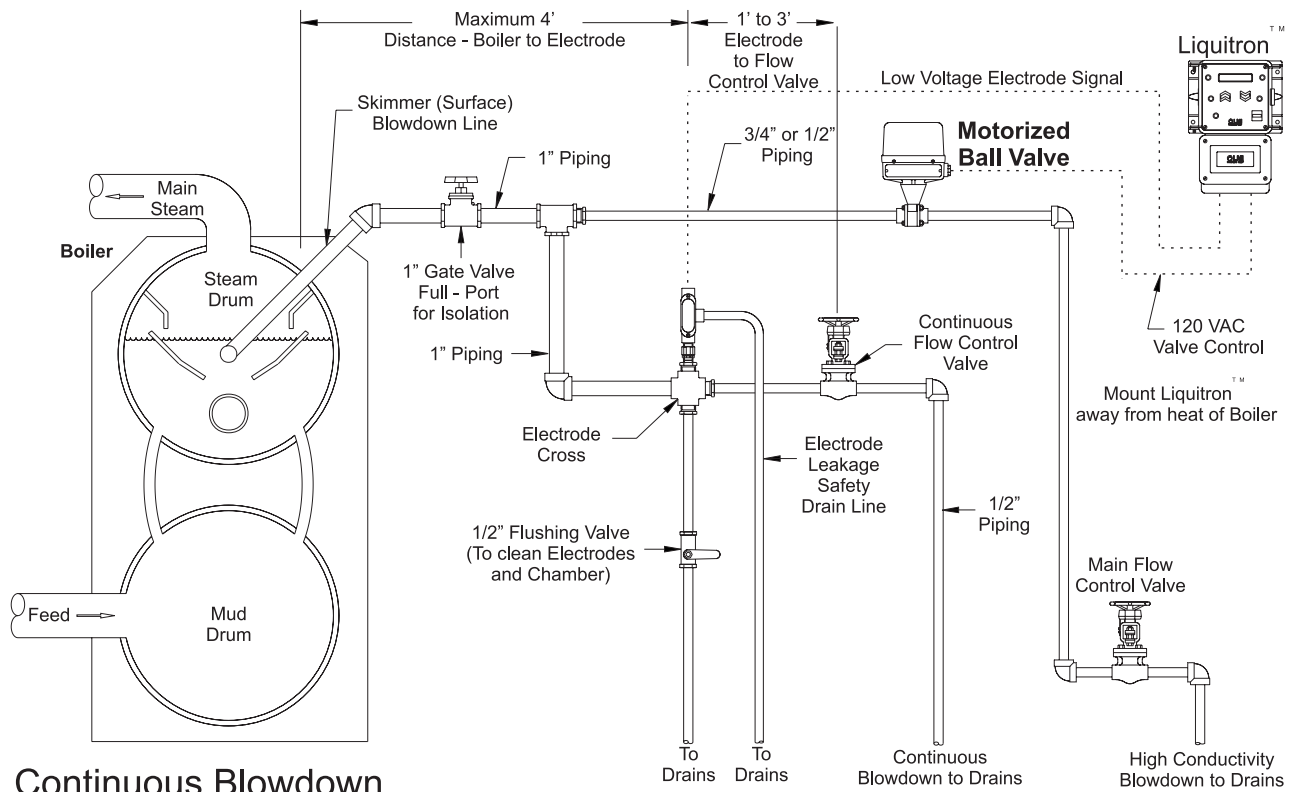

Continuous Blowdown

Continuous Blowdown [Sampling] is recommended for boilers with blowdown requirements of over 5,000 lbs/hr. This system allows for continuous monitoring and control of boiler water conductivity.

Recommended System Installations

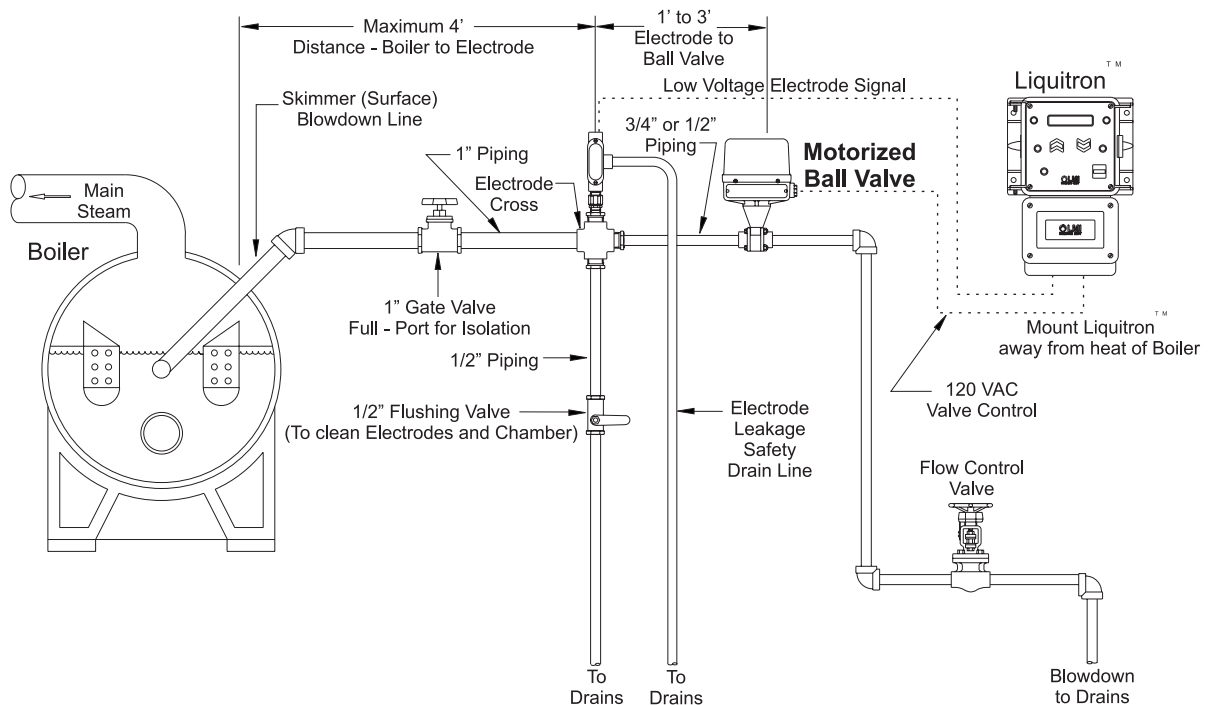

Timed Blowdown

Timed Blowdown [Sampling] is recommended for smaller boilers with blowdown requirements of less than 5,000 lbs/hr. The boiler water is periodically sampled for conductivity. This is done in order to maintain the boiler water level and not **“over blow”** the boiler.