

Information Sheet

Time Switch

General Description

This compact digital time switch is capable of operating two pumps or one pump and one valve for simultaneous operation of feed and bleed. It provides precise timing with the flexibility of daily and/or weekly programming. Simple and fast setting by means of push buttons and display prompts.

Features

- 24 hour/7 day timing combined 8 on/off operations daily
- Repeat programs provide up to 56 switching cycles per week
- Minimum time setting: 1 minute
- Lithium battery provides minimum 5 year reserve (unpowered)
- 24 hour display (military or AM/PM)
- Manual override
- Skip a day function

Setting Options

- Time of day
- Single day
- Repeat programs for daily recurring switching times
- 1-2-3-4-5 (Monday through Friday)
- 1-2-3-4-5-6 (Monday through Saturday)
- 1-2-3-4-5-6-7 (Monday through Sunday)
- 6-7 (Saturday and Sunday)
- Skip function for skipping all the switching programs of the next calendar day
- Reset function for clearing the whole switching program

Technical Data

Operating Voltage:	120 VAC, 50/60 Hz
Rated Power:	3.5 VA
Switching:	SPST, SPDT
Connections:	Three- 115 V receptacles (Timer), One- 115 V receptacle (Constant power)
Switch Rating:	16 amps @ 45° C, 10 amps @ 55° C
Operating Temp.	14°F (-10°C) to 131°F (55°C)

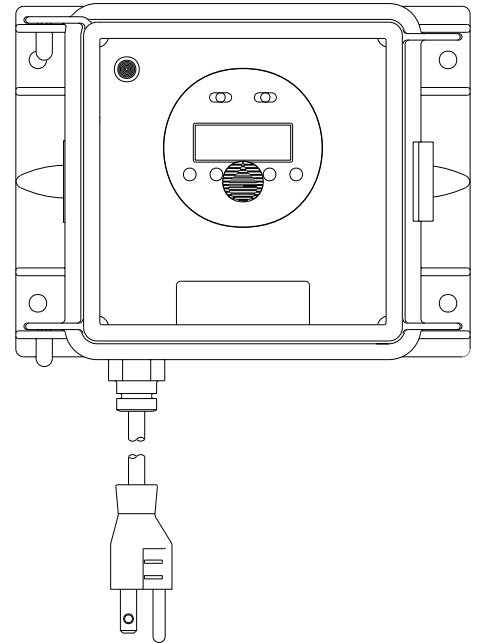

8 Post Office Square
Acton, MA 01720 USA
TEL: (978) 263-9800
FAX: (978) 264-9172
<http://www.lmipumps.com>



Instruction Supplement

Time Switch

(LMI Part Number 33424)

Dimensions & Mounting

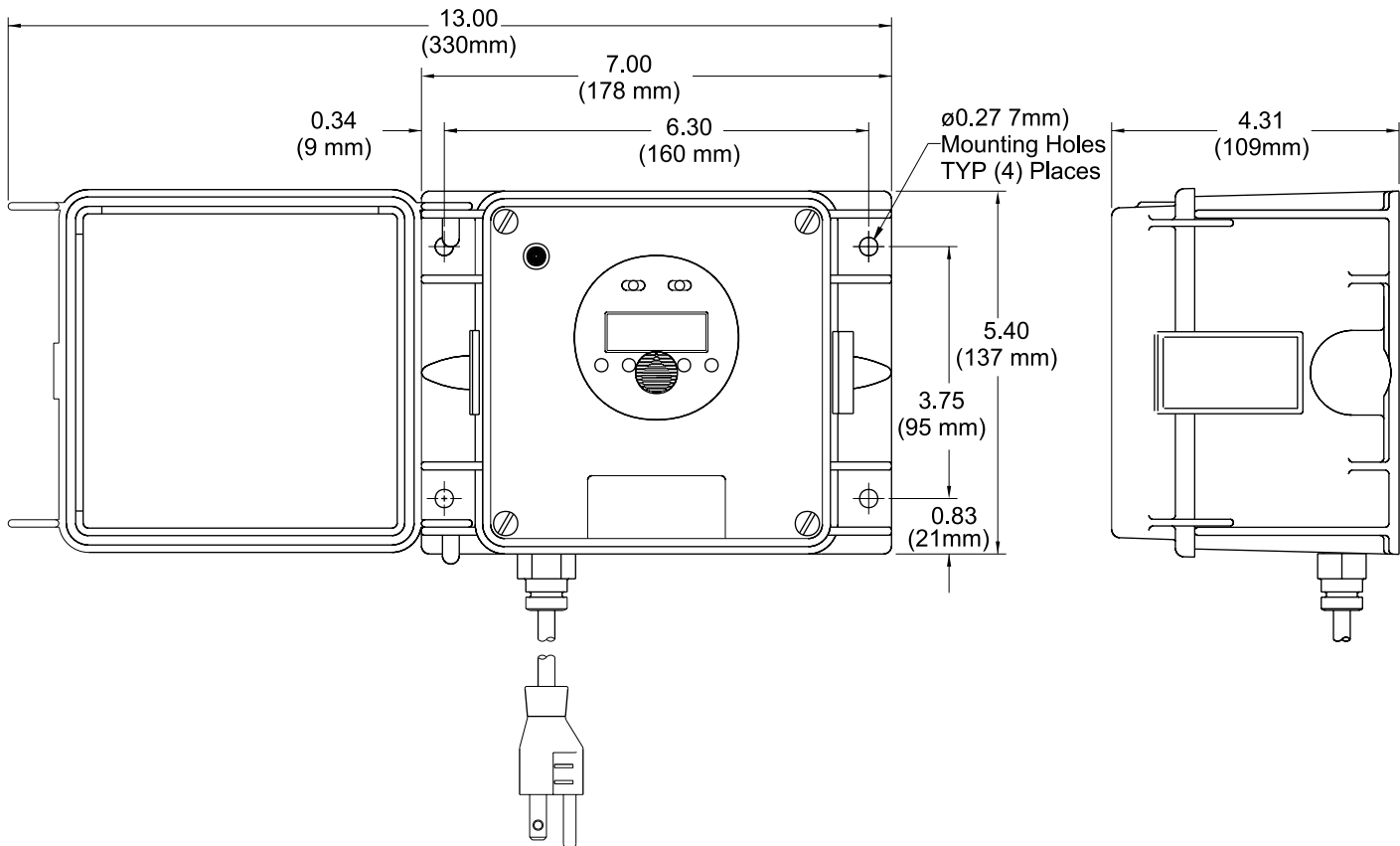

Setting Instructions

- Set Time & Day** Slide set switch to ☉. Press “1.7” button until arrow points to the correct day (1=Monday). Press “h” then “m” buttons to set correct time. PM (P) indicator shows noon to 11:59 PM. Slide set switch to run. Clock colon will blink.
- Set Switch On Cycle** Slide set switch to “P”. A “1” indicates the first switch cycle and a “bulb” indicates a switch-on (circuit closes). Press “1.7” button until arrows point to selected day(s) for this cycle. Press “h” and “m” buttons to show switch-on time, noting PM Indicator.
- Set Switch** With set switch at “P”, press Ⓟ button, note switch cycle off. Cycle number changes to 2 bulb blanks, indicating switch-off (circuit opens), press “1.7” button to match day(s) set for switch cycle “1”. Press “h” and “m” buttons to select switch-off time. Repeat steps up to 8 on/off events, slide set switch to run, clock colon will blink.
- Autorun** Run mode set time, day, and desired switch cycles, slide set switch to run and mode switch to auto, switching begins with next switch-on set time.
- Override On** Slide mode switch to “1”. Switch remains on indefinitely (circuit closed).
- Override Off** Slide mode switch to “O”. Switch remains off indefinitely (circuit open).
- Skip Cycle** In automatic run mode, press button. The next calendar day is skipped.
- Setting Error** If “EEE” appears, a setting error exists, the switch cycle number in error is shown. Slide set switch to “P” press Ⓟ button until cycle is shown, review this and the following setting to correct error, slide set switch to run.
- Clear Any Setting** Setting slide set switch to “P”. Press button to show switch cycle to clear
- Clear All** To erase all settings, press “R”.