

7000 Series Multi-Parameter Controller



Flexible Control with LMI Connect™ smart monitoring service

The new LMI LIQUITRON™ 7000 Series Multi-Parameter controller series provides conductivity, pH, and ORP monitoring from a single unit. Conveniently maintain water quality with an easy to use controller to ensure efficient chemical usage and maximum value.



Powerful control at your fingertips

Multi-parameter control flexibly serves a wide range of cooling tower, boiler, and other applications

Integrated cellular connection included in all models at launch (free upgrade for all hardware)

LMI Connect, Smart Monitoring Service fully integrates wireless connection, notifications and alerts, remote monitoring, control, reporting, and compliance

Remote software upgrades allow all devices to run the latest software release

Applications:

- Boilers
- Chlorination / De-chlorination
- Cooling Towers
- Environmental
- Food Processing
- Metal finishing
- Waste Neutralization

Features and Benefits:

- Multi-parameter controller provides conductivity, pH, and ORP control
- Available with (optional) cloud based **LMI Connect™** Technology provides process analytics and mobile access
- Durable construction to withstand challenging environments
- Easy to install, configure, monitor, and maintain
- Accurate and reliable performance ensures consistent results

Product Code

DM7	X	X	X	X	
Controls					
	Connectivity				
	Cellular*	5			
		Pump Power Cables			
		None (hardwired)	0		
		4 x US 115V	1		
			Unit Power Cord		
			None	0	
			US 115V	1	
			DIN 230V	3	
			UK 230V	5	
			Aust/NZ 230V	6	
				Cellular Type	
				US only	a
				Non-US	b

Note: Pigtails but no power cord is not an option.

*90-day FREE trial of LMI Connect



Input Power	115/230 VAC 50/60 Hz
Relay Output	Pumps (x4), blowdown valve, alarm relay. Voltage/Frequency same as input
Signal Input	Flow meter (x2), Flow Switch, Tank Low (x4)
Signal Output	Pulse Out (x2), 4-20 mA (x2)
Pump Power	Hardwired or pigtails
Display	7" Capacitive Touch
Remote Connectivity	CDMA for US and GSM globally
Applications	Cooling Tower, Boiler Feed, pH, ORP, Custom
Probes and Sensors	Conductivity (1 or 1.5 cell constant), pH, ORP, Temperature, Flow Switch
Controls	Blowdown, Biocides, Acid/Base, Inhibitor with 4 modes, Oxidizer/Reducer
Languages	English, Spanish, German, Chinese, Portuguese, French
Data Logging	Data recorded every minute transferable to USB (1 year capacity)
Software	Updatable via USB or LMI Connect™
Enclosure	NEMA 4X, IP65 (hardwired); NEMA 12, IP 52 (pigtails)
Certifications	ETL, CE

Accessories

Description	Part Number
3 Slot Flow Cell, Sample Valve	56566
Probe, Cond, Temp, 20 ft Cable, Pt Conductivity, Temperature	56567
Flow Switch ASY, 1.5m Cable, F/SW, PVC Tee, Adapt 3/4" NPT	56568
Cable, 20 ft pH/ORP - BNC to Tinned Leads	56572
Probe, pH w/out Cable	56569
Probe, ORP w/out Cable	56570
Probe, Temp, 20 ft Cable - Incl 3/4" Fitting	56573
Lid & Clear Cover	55578
Replacement, Wall Mount ASY	56574
Tee, 1" NPT w/ 3 3/4" Reducers	56954

Description	Part Number
Cellular Antenna, Omnidirectional	56437
Boiler Probe Assembly with 1" Cross & 1/2" Conduit	34761
Boiler Probe	34759
Cross, 1"	34760
Conduit Box Assembly	34796
Nipple, 1/2" Conduit	35058
Fitting, 1/2" Conduit	35059
Orifice Union w/Plates (pre-drilled)	35208
Power Supply, Display, and Mounting Bracket with screws	55577

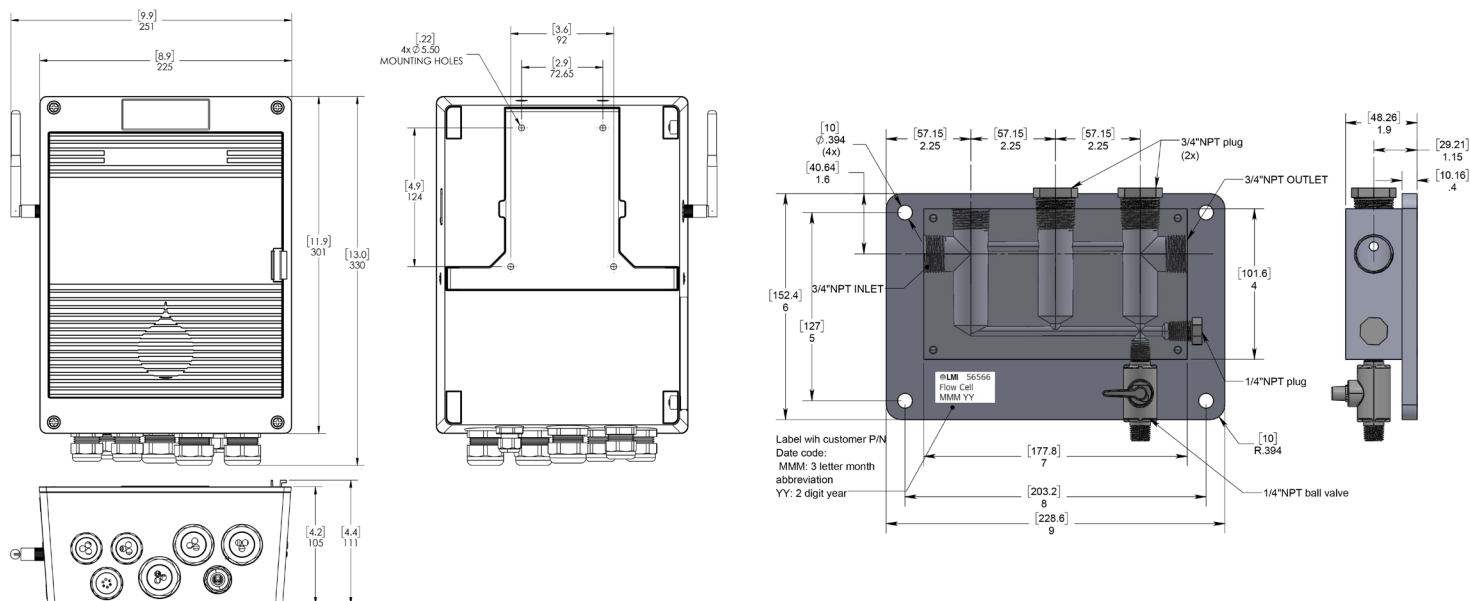

We are a proud member of Accudyne Industries, a leading global provider of precision-engineered, process-critical and technologically advanced flow control systems and industrial compressors. Delivering consistently high levels of performance, we enable customers in the most important industries and harshest environments around the world to accomplish their missions.



LIQUITRON is a trademark of Milton Roy, LLC

Literature #DM7000 7/2018

©2018 Milton Roy, LLC



an Accudyne Industries brand