

# Introducing the New Multifunction Valve

Product News

## MFV adds Performance, Safety, and Convenience to a metering pump system

The new multifunction valve, MFV, extends your metering pump to provide critical functionality such as back pressure, pressure relief, priming and other key functions into a single valve. The integrated design mounts directly on the liquid end of the pump as a cost effective solution to address common challenges in chemical metering applications.



### Features & Benefits:

- **Performance:** Back pressure improves system performance by providing constant pressure against the pump. Pressure Relief protects the pump from overpressure by releasing fluid through a relief port in the event of excessive discharge line pressure.
- **Safety:** Anti-Siphon prevents the discharge line from syphoning liquid from the supply tank in most application. Burp eliminates the valve's back pressure allowing the pump to run at atmospheric pressure.
- **Convenience:** Prime diverts flow through the relief line to the tank, thus allowing air to flow from the head. Drain Line allows discharge line to the tank, leaving it to open atmosphere.

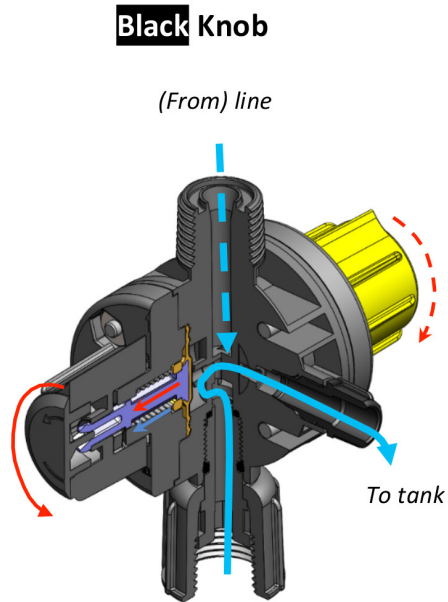
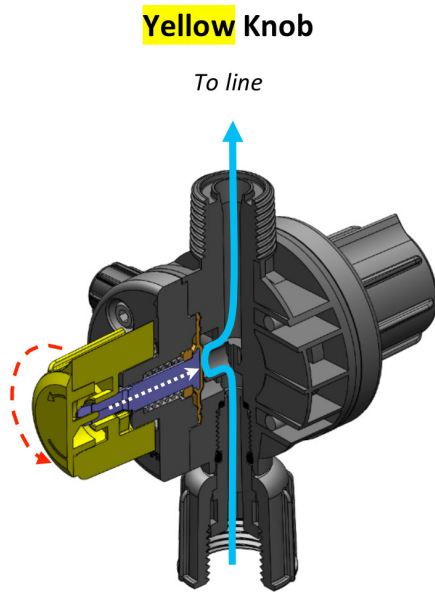

Function	Action
Back-Pressure	Automatic
Anti-Siphon	Automatic
Burp	Turn Yellow

From Pump

Function	Action
Pressure Relief	Automatic
Prime	Turn Black
Drain Line	Turn B & Y

From Pump

### Questions?

For more information, contact your local stocking distributor.



**Standard Version**  
*Designed for General Applications*



**Pro Version- Coming soon!**  
*Designed for Sodium Hypochlorite Applications*



MFV Kit Numbers	Description	MFV Kit Numbers	Description
57708	MFV Kit, 150 PSI, ½" NPT, Polyprel	58062	MFV Kit, 150 PSI, ½" NPT, Polyprel
57710	MFV Kit, 250 PSI, ½" NPT, Polyprel	58064	MFV Kit, 250 PSI, ½" NPT, Polyprel
57709	MFV Kit, 150 PSI, ½" NPT, PTFE		
57711	MFV Kit, 250 PSI, ½" NPT, PTFE		
Retrofit Kit Numbers	Description	Retrofit Kit Numbers	Description
57706	MFV Retrofit Kit, 150 PSI	58060	MFV Pro Retrofit Kit, 150 PSI
57707	MFV Retrofit Kit, 250 PSI	58061	MFV Pro Retrofit Kit, 250 PSI

**Accessories:**

**MFV Kits:** Install a multifunction valve to the standard discharge valve on your LMI pump. Includes multifunction valve and tubing.

**Retrofit Kits:** Upgrade a previous generation 3-Function or 4-Function valve on your LMI pump. Includes multifunction valve, tubing, additional fittings, and O-rings.



**About Ingersoll Rand**

Ingersoll Rand (NYSE:IR), driven by an entrepreneurial spirit and ownership mindset, is committed to helping make life better. We provide innovative and mission-critical industrial, energy, medical and specialty vehicle products and services across 40+ respected brands designed to excel in even the most complex and harsh conditions where downtime is especially costly. Our employees connect to customers for life by delivering proven expertise, productivity and efficiency improvements. For more information, visit [www.IRCO.com](http://www.IRCO.com).

Contact your local representative to find out more.

[www.lmipumps.com](http://www.lmipumps.com)



Literature #IR-MFV Rev 9/2020