



*For units shipped after March 2021 (SN>0321)
 *See document [2017.B] for earlier version

LE-9x0xx & LE-9x8xx (AutoPrime™)

When pumping solutions, make certain that all tubing is securely attached to the fittings. It is recommended that tubing or pipe lines be shielded to prevent possible injury in case of rupture or accidental damage. Always wear protective clothing and face shield when working on or near your metering pump.

Note: See parts list for materials of construction

A. INSTALLING INJECTION CHECK VALVE (FIGURE 1)

1. The Injection Check Valve prevents backflow from a treated line. Install the injection check valve at the location where chemical is being injected into the system.
2. Any size Female NPT fitting or pipe tee with a reducing bushing to 1/2" Female NPT will accept the injection check valve. PTFE tape should only be used on threads that are connected with pipes.
3. When installing the Injection Check Valve, be sure to position it so that the valve enters the bottom of your pipe in a vertical position. Variations 40° left and right are acceptable.

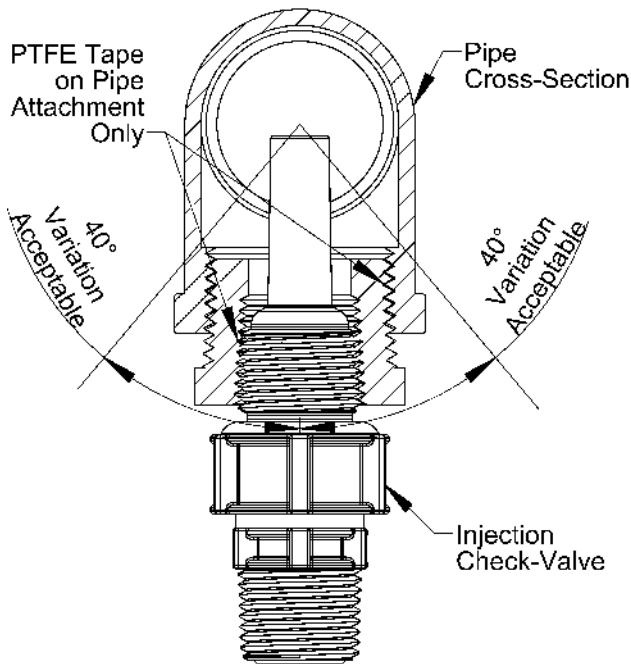

FIGURE 1

3. Position female Ferrule about one inch (25 mm) from end of tubing.
4. For 1/4" or 6 mm OD tubing, cut tubing so that 1/4" to 3/8" (5-10 mm) protrudes from the female Ferrule. For all other tubing push the tube to the bottom of the groove in the male Ferrule. Then slide the female Ferrule down into the male Ferrule.
5. Firmly hand tighten the coupling nut onto the fitting.

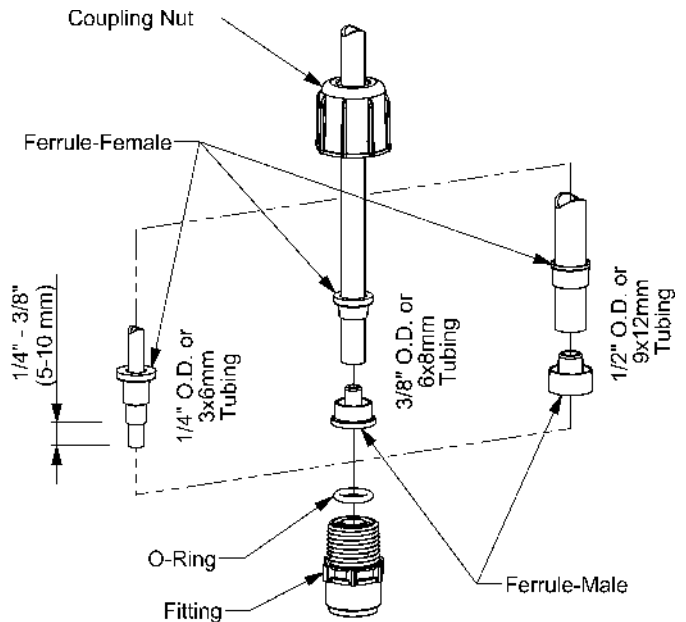

FIGURE 2

DO NOT USE CLEAR VINYL TUBING ON THE DISCHARGE SIDE OF THE PUMP.

DO NOT USE PLIERS OR PIPE WRENCH ON COUPLING NUTS OR FITTINGS.

B. CONNECTING DISCHARGE TUBING (FIGURE 2)

Please note: The chemical discharges through the discharge valve which is mounted to the front of the AUTOPRIMETM liquid end, as seen in Figure 3.

Note: Cut tubing to length needed for discharge line.

1. Route tubing from the injection check valve to the metering pump, making sure it does not touch hot or sharp surfaces, or is bent so sharply that it kinks.
2. Put coupling nut over tubing.

C. CONNECTING SUCTION TUBING

1. Cut suction tubing to a length so that the foot valve hangs just above the bottom of the solution container. Maximum recommended vertical suction lift is 5 ft (1.5m).
2. Follow same procedure in connecting suction tubing to suction valve and foot valve (see B. Connecting Discharge Tubing).



201 Ivyland Road Ivyland,
 PA 18974 USA
 TEL: (215) 293-0401
<http://www.lmipumps.com>

LE – 9x0xx & LE – 9x8xx

Key Number	Description	Part Number	QUANTITY				QUANTITY			
			910xx	920xx	930xx	940xx	918xx	928xx	938xx	948xx
10	Pump Head AutoPrime™	48422	1							
		48423					1			
		48425		1						
		48426						1		
		48428			1					
		48429							1	
		48431				1				
		48432								1
40	O-Ring	48349	5	5	5	5	5	5	5	
90	O-Ring	39413	6	6	6	6	6	6	6	
100	O-Ring	36103	5	5	5	5	5	5	5	
190	Liquifram™	48186	1				1			
		48187		1				1		
		48188			1				1	
		48189				1				1
230	Injection Check Valve Body	48617	1	1	1	1	1	1	1	
250	Ceramic Weight	10322	1	1	1	1	1	1	1	
260	Foot Valve Coupling	36204	1	1	1	1	1	1	1	
270	Foot Valve Strainer	10123	1	1	1	1	1	1	1	
350	Tubing, Suction & Discharge 9xxxI ONLY	25636-16	1	1*			1	1*		
		10342-16		1#	1	1		1#	1	1
356	Tubing, AutoPrime™	10142-10	1	1	1	1	1	1	1	
602	Suction Check Valve	49166	1				1			
		49163		1	1	1		1	1	1
603	Cartridge Valve	48545	3				3			
		48546		3	3	3		3	3	3
606	Liquid End Hardware	48702	1	1	1	1	1	1	1	
607	Foot Valve	49164	1				1			
		49165		1	1	1		1	1	1
608	Injection Valve	48728	1	1	1	1	1	1	1	
609	AutoPrime™ Disch. Check Valve	48704	1				1			
		48705		1	1	1		1	1	1
610	AutoPrime™ Disch. Cartridge Valve	48706	1				1			
		48707		1	1	1		1	1	1
611	AutoPrime™ Shuttle Valve	48708	1	1	1	1	1	1	1	
612	AutoPrime™ Cartridge Valve	48709	1	1	1	1	1	1	1	
613	Tubing Connection Kit (inch) 9xxxI	77382	4	4*			4	4*		
		77383		4#	4	4		4#	4	4
	Tubing Connection Kit (metric) 9xxxM	77378	4	4*			4	4*		
		77379		4#	4	4		4#	4	4
614	Tubing Connection Kit 9xxxI	77384	1	1	1	1	1	1	1	1
	Tubing Connection Kit 9xxxM	77380	1	1	1	1	1	1	1	1
615	Single Ball Check Valve Fitting	48787	2	2	2	2	2	2	2	
616	Double Ball Check Valve Fitting	48791	3	3	3	3	3	3	3	
617	Injection Valve Cartridge	48795	1	1	1	1	1	1	1	
620	MFV Assenbly Kit 9x0Hx and 9x8Hx	58064	1				1			
		58062		1	1	1		1	1	1
622	Cartridge Valve	48545	1	1	1	1	1	1	1	

ROYTRONIC® A/P+

* EXCEL™ AD

LE-9x0xx & LE-9x8xx

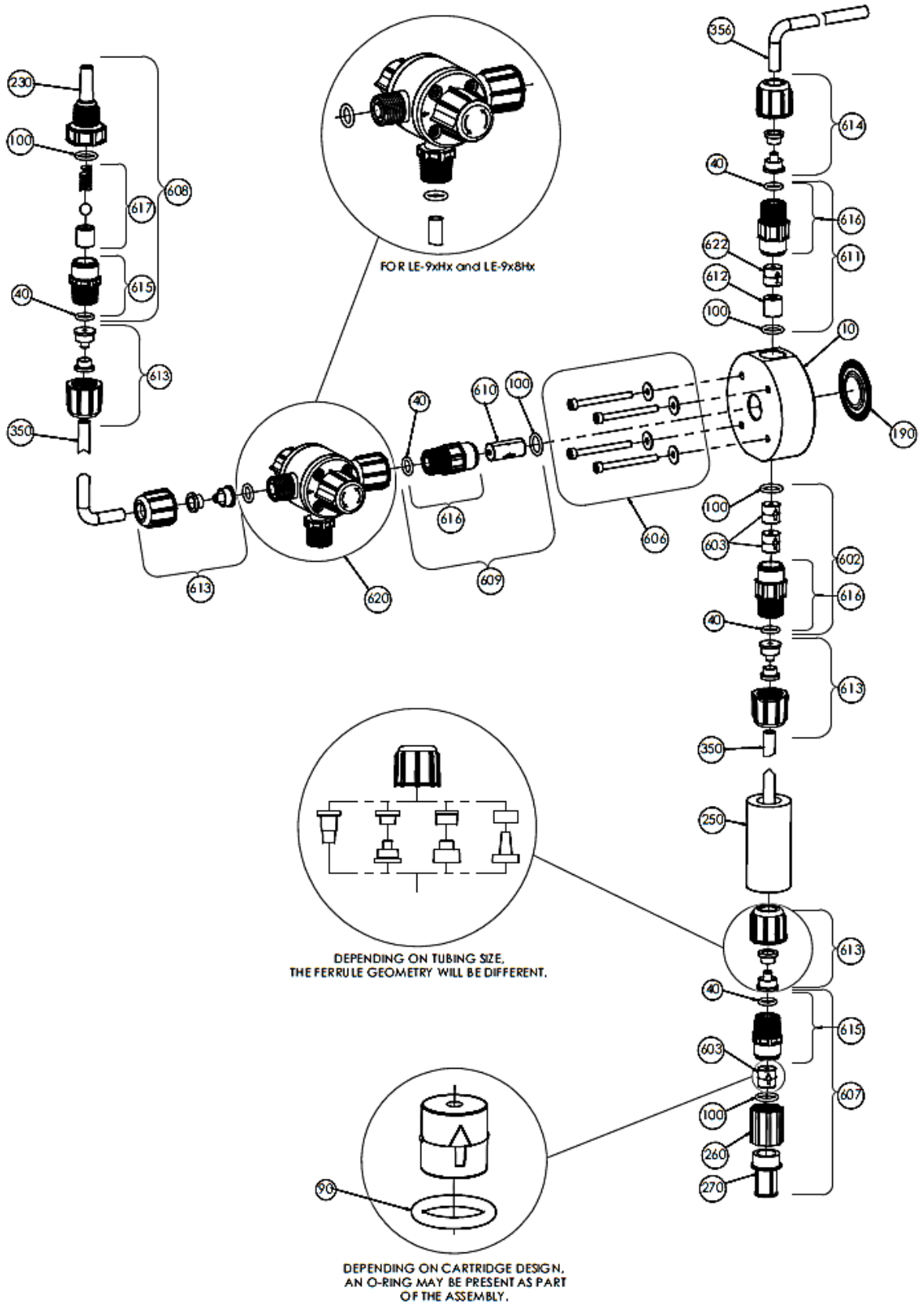

FOR LIQUID ENDS 9xxAx

D. CONNECTING AUTOPRIME™ TUBING

1. Using 1/2" O.D. polyethylene tubing, cut AUTOPRIME™ tubing to length so that it returns to the solution tank. This tubing must not be submerged in the solution.
2. Follow the same procedure in connecting AUTOPRIME™ tubing to the AUTOPRIME™ valve (see **B. Connecting Discharge Tubing**).

E. PRIMING FOR AUTOPRIME™ LIQUID ENDS

When all precautionary steps have been taken, the pump is mounted, and the tubing is securely attached, you may now start priming the pump.

1. Plug in or switch the pump on.
2. While the pump is running, set at 100% speed and 100% stroke length.
3. The suction tubing should begin to fill with solution from the tank.
4. The pump is now primed.

Note: The pumps are normally self priming if suction lift is less than 5 feet (1.5 meters), check valves are wet (there is usually water in the pump head when shipped from the factory), and the steps above are followed. If the pump does not self prime, you can choose one of 2 ways to help prime:

1. Remove the AUTOPRIME™ valve and cartridges and slowly pour water or solution into the pump head until it is filled. Replace cartridges and AUTOPRIME™ valve and repeat steps above.
2. Temporarily improve suction conditions by pumping from a container closer to or above pump.

F. DEPRESSURIZING THE DISCHARGE LINE AND PUMP HEAD

ALWAYS wear protective clothing, face shield, safety glasses and gloves when performing any maintenance or replacement on your pump.

1. Be sure the Injection Check Valve is properly installed and is operating. If a shut off valve has been installed downstream of the Injection Valve, it should be closed.

2. Line Depressurization:

To reduce the risk of chemical splash during disassembly or maintenance, all installations should be equipped with line depressurization capability. Installing a Multifunction Valve is one way to include this capability. Refer to the operating instructions of the valve or device.



When tubing connections are loosened, chemical will drain from the line. Use appropriate safety precautions to avoid contact with chemical.

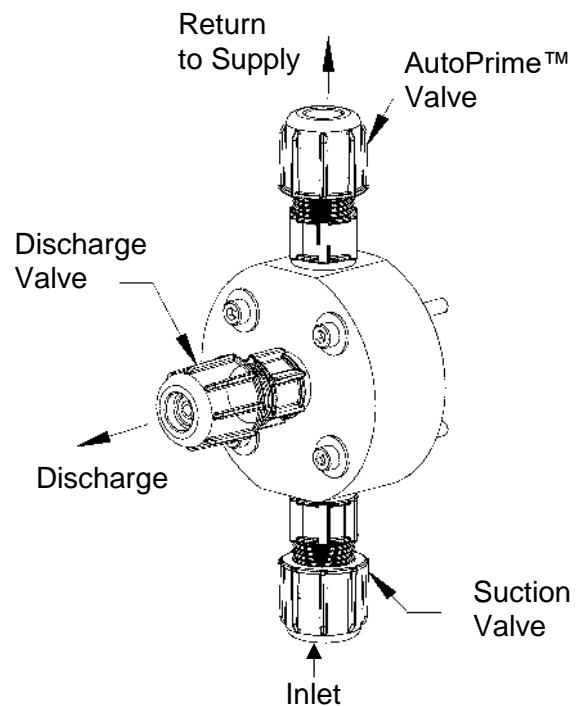

FIGURE 3

FOR LIQUID ENDS 9xxHx

G. CONNECTING AUTOPRIME™ TUBING

1. Using 1/2" O.D. polyethylene tubing, cut AUTOPRIME™ tubing to length so that it returns to the solution tank. This tubing must not be submerged in the solution.
2. Follow the same procedure in connecting AUTOPRIME™ tubing to the AUTOPRIME™ valve (see **B. Connecting Discharge Tubing**).

H. PRIMING WITH MULTIFUNCTION VALVE

1. Connect pressure relief tubing to the pressure relief port (Figure 3). Route tubing to the solution tank. This tubing must not be submerged in the solution.

When all precautionary steps have been taken, the pump is mounted, and the tubing is securely attached, you may now start priming the pump.

2. Turn black knob about 1/8 turn CCW to stop point to open bypass port.
3. Set pump at 100% speed and 100% stroke length. Start pump. When fluid has been flowing through the bypass port tubing for 10-20 seconds, the pump is primed.
4. Stop pump and return black knob to normal position.

Note: The pumps are normally self priming if suction lift is less than 5 feet (1.5 meters), check valves are wet (there is usually water in the pump head when shipped from the factory), and the steps above are followed. If the pump does not self prime, you can choose one of 2 ways to help prime:

1. Remove the AUTOPRIME™ valve and cartridges and slowly pour water or solution into the pump head until it is filled. Replace cartridges and AUTOPRIME™ valve and repeat steps above.
2. Temporarily improve suction conditions by pumping from a container closer to or above pump.

I. DEPRESSURIZING THE DISCHARGE LINE

ALWAYS wear protective clothing, face shield, safety glasses and gloves when performing any maintenance or replacement on your pump.

When preparing to maintain the pump or any component in the discharge line, the multifunction valve is used to depressurize the line. Be sure an injection check valve is properly installed and is operating, and that all tubing connections on the multifunction valve are secure.

Be sure your relief tubing is connected to your pressure relief port on the multifunction valve and runs back to your solution drum or tank.

1. Turn off the pump.
2. If any valves have been installed downstream of the pump, close them.
3. If the supply tank for the pump is higher than the pump head, fluid will flow through unless a suction line valve is closed.
4. Turn the black knob on the multifunction valve about 1/8 turn CCW to its open position. This relieves pressure between the pump and the multifunction valve.
5. To release line pressure, while the black knob is in the open position, turn the yellow knob and hold open until fluid flow through the bypass port stops.



When tubing connections are loosened, chemical will drain from the line. Use appropriate safety precautions to avoid contact with chemical.

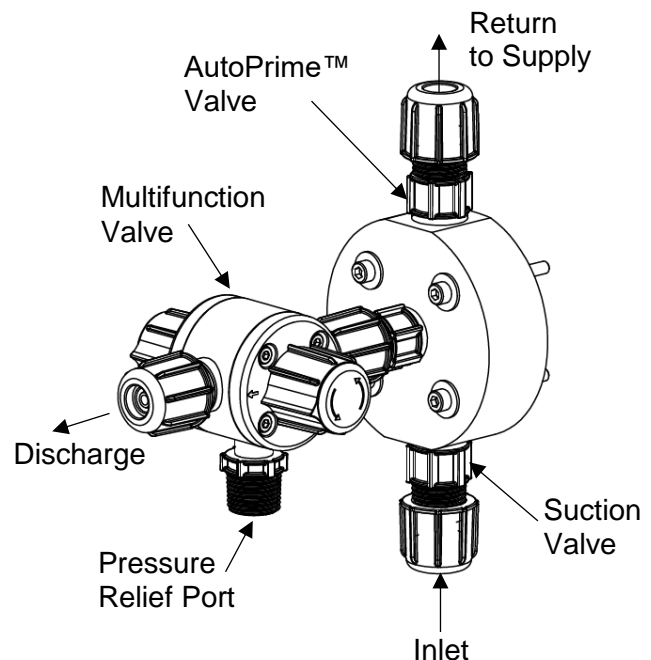

FIGURE 4

REFER TO YOUR ELECTRONIC METERING PUMP INSTRUCTION MANUAL FOR ADDITIONAL INSTRUCTIONS AND PRECAUTIONS. You may contact your local LMI Distributor for additional information or visit LMI on the web at www.lmipumps.com